

# HURRICONE

Cordless Floor Dryer



## Owner's Manual

Model: HUR6000

The HURRICONE™ Cordless Floor Drying Cone Dolly, with Safety Cone, not only warns pedestrians of potential slip hazards, but also aids in drying wet floors with a continuous 360 degree curtain of air. The HURRICONE™ should be used in any area that pedestrians will encounter wet floors either from continual foot traffic bringing in rain or snow, or wet from spills and mopping floors.

The HURRICONE™ accepts the following brands of Safety Cones:

- HURRICONE™ Brand Safety Cones
- Rubbermaid® 36 in. Safety Cones
- American Allsafe® / Lamba® 36 in. Safety Cones

**PLEASE READ THIS MANUAL THOROUGHLY  
BEFORE OPERATING PRODUCT**

©20011 Beach Sales & Engineering LLC All rights reserved

HURRICONE™ is a registered trademark. Designed & Engineered in the USA and custom-manufactured in China.

Beach Sales & Engineering LLC  
Mansfield, Ohio 44906 U.S.A.

US AND FOREIGN PATENTS PENDING

The HURRICONE™ Cordless Floor Drying Dolly has been carefully engineered and manufactured to give you dependable operation. Please read this manual thoroughly before operating the HURRICONE™ unit, as it contains the information you need to become familiar with its features and to obtain the performance that will bring you continued service.

Please keep this manual on file for further reference.

## **WARNING**

- DO NOT USE NEAR TOXIC MATERIALS, EXPLOSIVE LIQUIDS OR VAPORS
- STORE INDOORS, DO NOT EXPOSE TO RAIN OR SNOW
- FOR SAFE OPERATION, READ AND UNDERSTAND USERS MANUAL PRIOR TO USE
- USE ONLY GENUINE HURRICONE™ BATTERY PACK
- USE ONLY GENUINE HURRICONE™ BATTERY CHARGER
- DO NOT LIFT THE UNIT BY SAFETY CONE. CONE DOLLY CAN SEPARATE FROM CONE AND CAUSE DAMAGE TO UNIT OR PERSONAL INJURY.
- DO NOT USE CHARGER WHILE HURRICONE™ UNIT IS IN USE OR IN THE PROXIMITY OF PEDESTRIANS, POWER CORDS ARE POTENTIAL TRIP HAZARDS.
- DO NOT USE HURRICONE™ WITHOUT SAFETY CONE ATTACHED.

Although your HURRICONE™ Cordless Floor Drying Cone Dolly may arrive partially charged from the factory, we recommend fully charging the unit before the first use.

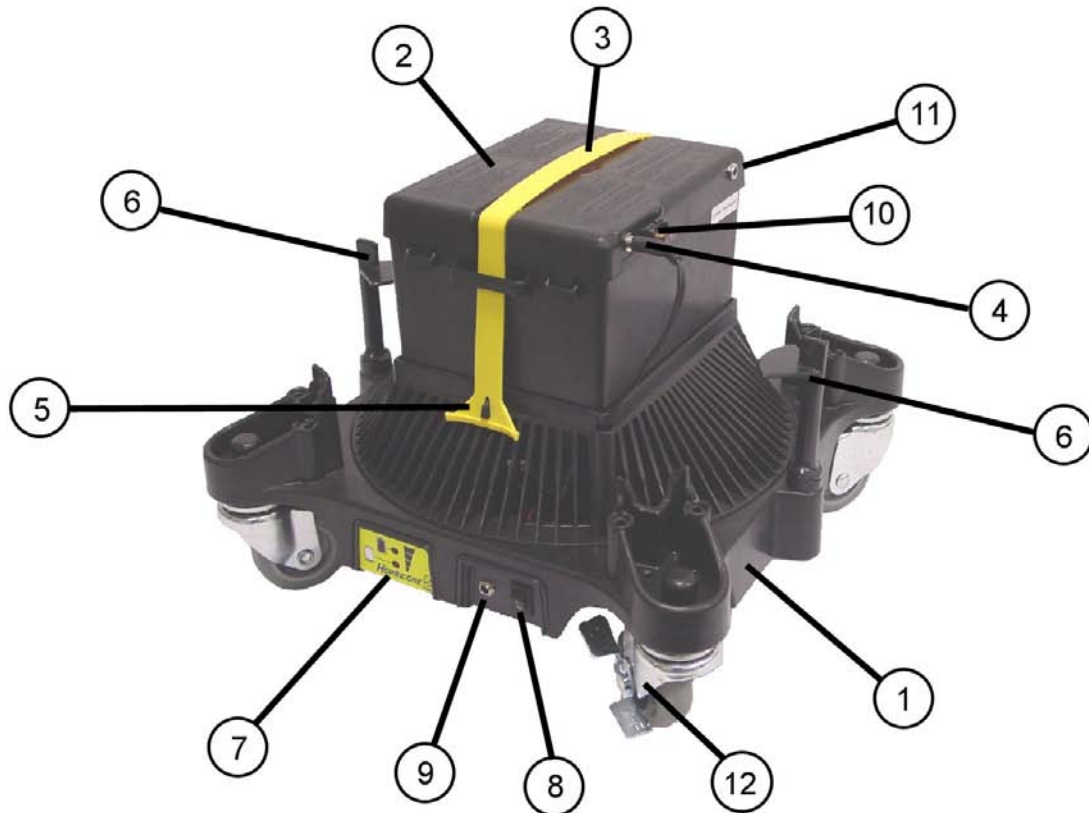

## HURRICONE™ COMPONENTS

1. Cone Dolly
2. Battery Pack
3. Battery Carrying Strap
4. Connecting Barrel Plug
5. Strap Mounting Post
6. Cone Holders
7. Battery Level Indicator
8. On / Off Switch
9. Charging Jack
10. 5 Amp Fuse
11. Optional Charging Jack
12. Locking Caster
13. AC Charger
14. LED Charging Indicator

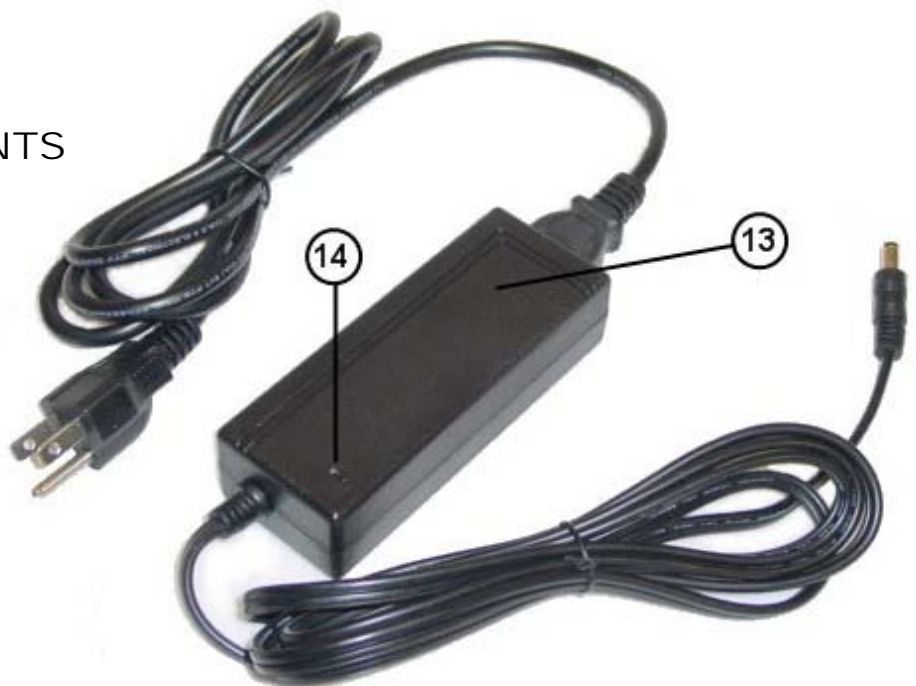

## • BATTERY PACK

The battery system in this unit is designed to operate your HURRICONE™ at a proper drying speed for up to 8 hours of continuous use. Although the unit will continue to run after 8 hours, the unit may not generate enough air movement to effectively aid in drying floors.

The Battery Pack in the HURRICONE™ was designed to be removed from the Cone Dolly and recharged, then replaced with a freshly charged Battery Pack so that the HURRICONE™ can be in operation 24 hours a day if needed. The Battery Pack can also be charged without removal from the Cone Dolly through the Charging Jack.

Under normal use and when properly maintained, the Battery will produce superior run time. When the unit fails to run for the specified amount of time, battery replacement is recommended.

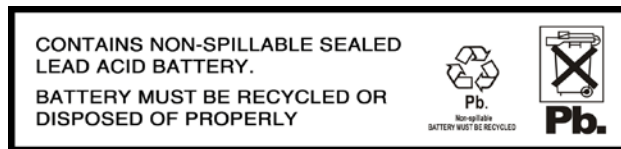

The Battery Pack is supplied with a 5 Amp Fuse for protection. Only replace the fuse with a 5 amp fuse.

## BATTERY PACK INSTALLATION and REMOVAL

### INSTALLATION

To Install Battery Pack, place Battery Pack in Cone Dolly, push Battery Carrying Strap down, and push ends of Battery Carrying Strap over Mounting Posts to secure Battery Pack. Connect Barrel Plug from Cone Dolly to jack in Battery Pack Lid. Attach Safety Cone (see Attachment and Removal of Safety Cones).

### REMOVAL

Remove Safety Cone from Main Unit (see Attachment and Removal of Safety Cones). Locate Connecting Barrel Plug. Grasp Barrel Plug and disconnect it from Jack in Battery Lid. Be careful not to pull from the wires. Pull from the Barrel Plug. Locate Battery Carrying Strap. Remove Battery Carrying Strap from Main Unit by pulling the bottom of the Battery Carrying Strap off of the Mounting Posts. Pull up on the Battery Carrying Strap and remove Battery Pack from Cone Dolly.

## • CHARGING

Do not store or use AC Charger while on the floor, as it can become wet and short out. This will void your warranty.

During extended periods of nonuse, it is recommended to recharge the battery every 3 months.

**WARNING**- DO NOT USE AC CHARGER WHILE UNIT IS IN USE OR IN THE PROXIMITY OF PEDESTRIANS, POWER CORDS ARE POTENTIAL TRIP HAZARDS.

### CHARGING A BATTERY PACK WHILE IN DOLLY

Plug one end of the 120 Volt AC Charger into the Charging Jack on the Cone Dolly. Plug the other end into any standard 120 Volt AC wall outlet.

### CHARGING A BATTERY PACK THAT IS REMOVED FROM DOLLY

Remove Safety Cone from Cone Dolly (see Attachment and Removal of Safety Cones). Locate Connecting Barrel Plug. Grasp Barrel Plug and disconnect it from Jack in Battery Lid. Be careful not to pull from the wires, pull from the Barrel Plug. Remove Battery Pack from the Main Unit (see Battery Pack Installation and Removal). Plug one end of the 120 volt AC Charger into the Battery Lid Jack. Plug the other end into any standard 120 Volt AC wall outlet.

The red LED Charging Indicator Light will illuminate on the AC Charger to confirm that power is being supplied to the Battery Pack. The Battery Pack is fully charged when the Green LED Indicator Light is illuminated. Full charging will take approximately 8-9 hours. The Charger will automatically switch from charge mode to float / standby mode. The charger can be kept on the battery indefinitely.

## • BATTERY LEVEL INDICATOR

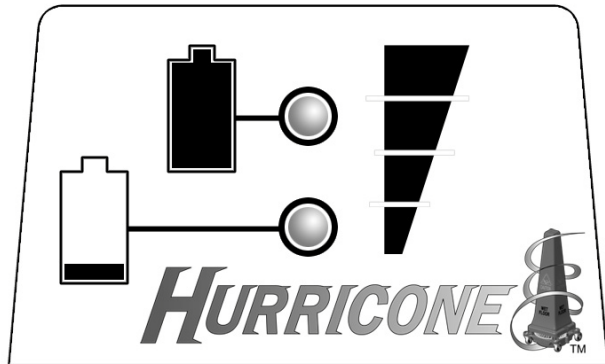

Your HURRICONE™ Dolly is equipped with a battery level indicator located on left side panel opposite the On/Off switch and Charging Jack.

- Green LED illuminates when unit is turned ON and battery is fully charged
- Red LED will start to blink when battery is low and needs recharged
- An Audible Tone will sound every 2 minutes during the low battery warning
- The unit will shut off automatically when the battery reaches an unusable level. Battery will need recharged at this time (See Charging Section)

## • ATTACHMENT & REMOVAL OF SAFETY CONES

### ATTACHMENT

Locate Cone Holders and rotate them 180 degrees. Place Safety Cone on dolly and rotate Cone Holders back into position over edge of Safety Cone.

### REMOVAL

Locate Cone Holders and rotate them 180 degrees. Remove Safety Cone from dolly and rotate Cone Holders back into position.

**WARNING**- DO NOT LIFT THE UNIT BY SAFETY CONE. CONE DOLLY CAN SEPARATE FROM CONE AND CAUSE DAMAGE TO UNIT OR PERSONAL INJURY.

### LOCKING WHEEL / CASTER

Your Cone Dolly is supplied with Locking Casters. We recommend using the Lock when the unit is in operation.

### USE OF ADDITIONAL SAFETY CONES

Additional Safety Cone may be stacked on the Cone Dolly for added convenience and mobility of additional cones. We recommend only stacking a maximum of 8 Safety Cones.

TO ORDER ADDITIONAL / REPLACEMENT  
BATTERY PACKS, SIGNS OR ACCESSORIES  
PLEASE CALL YOUR LOCAL DISTRIBUTOR OR  
CALL CUSTOMER SERVICE AT (419) 525-1010  
TO LOCATE YOUR LOCAL DISTRIBUTOR

# **BEACH SALES & ENGINEERING LLC Limited Warranty**

**WHAT IS COVERED:** Any defect in materials and workmanship.

**FOR HOW LONG:** 1 year from date of purchase – Proof of purchase required.

**WHAT WE WILL DO:** If your product is defective and returned within 30 days after the date it was purchased, we will replace it at no charge to you. If returned after 30 days but within 1 year of the date of purchase we will repair it or, at our option, replace it at no cost to you.

If we repair your product, we may use new or reconditioned replacement parts. If we choose to replace your product, we may replace it with a new or reconditioned one of the same or similar design. The repair or replacement will be warranted under our standard 1 year warranty.

**LIMITATIONS: IMPLIED WARRANTIES, INCLUDING THOSE OF FITNESS FOR A PARTICULAR PURPOSE AND MERCHANTABILITY, ARE LIMITED TO 1 YEAR FROM DATE OF PURCHASE. WE WILL NOT PAY FOR LOSS OF TIME, INCONVENIENCE, LOSS OF USE OF YOUR PRODUCT OR PROPERTY DAMAGE CAUSED BY YOUR PRODUCT OR ITS FAILURE TO WORK, OR AND OTHER INCIDENTAL OR CONSEQUENTIAL DAMAGES INCLUDING PERSONAL INJURY.**

Some states do not allow limitations on how long an implied warranty lasts or the exclusion or limitation of incidental or consequential damages, so the above exclusions or limitations may not apply to you.

**WARRANTY SERVICE:** To get warranty service for your product, Please call the Customer Service number at (419) 525-1010 to discuss your problem. If unit needs service or replacement, Customer service will give you a RETURN AUTHORIZATION NUMBER and advise you as to the address to return it to. No units will be accepted without a RETURN AUTHORIZATION NUMBER. You must provide proof of the date of purchase.

**WHAT THIS WARRANTY DOES NOT COVER:** AMONG OTHER THINGS THIS WARRANTY DOES NOT COVER DEFECTS RESULTING FROM ACCIDENTS, DAMAGE WHILE IN TRANSIT TO OUR SERVICE LOCATION, ALTERATIONS, UNAUTHORIZED REPAIR, FAILURE TO FOLLOW INSTRUCTIONS, MISUSE, FIRE, FLOOD, AND ACTS OF GOD. If your product is not covered by our warranty, call our customer service number at (419) 525-1010 to determine whether we will repair your product and other repair information, including charges. We, at our option may replace rather than repair your product with a new or reconditioned one of the same or similar design. The repair or replacement will be warranted for 1 year from date of service.

THIS LIMITED WARRANTY IS THE ONLY ONE WE GIVE ON YOUR PRODUCT, AND IT SETS FORTH ALL OUR RESPONSIBILITIES REGARDING YOUR PRODUCT. THERE ARE NO WARRANTIES WHICH EXTEND BEYOND THE DESCRIPTION SET FORTH ABOVE.

**STATE LAW RIGHTS:** This warranty gives you specific legal rights and you may also have other rights which may vary from state to state.